

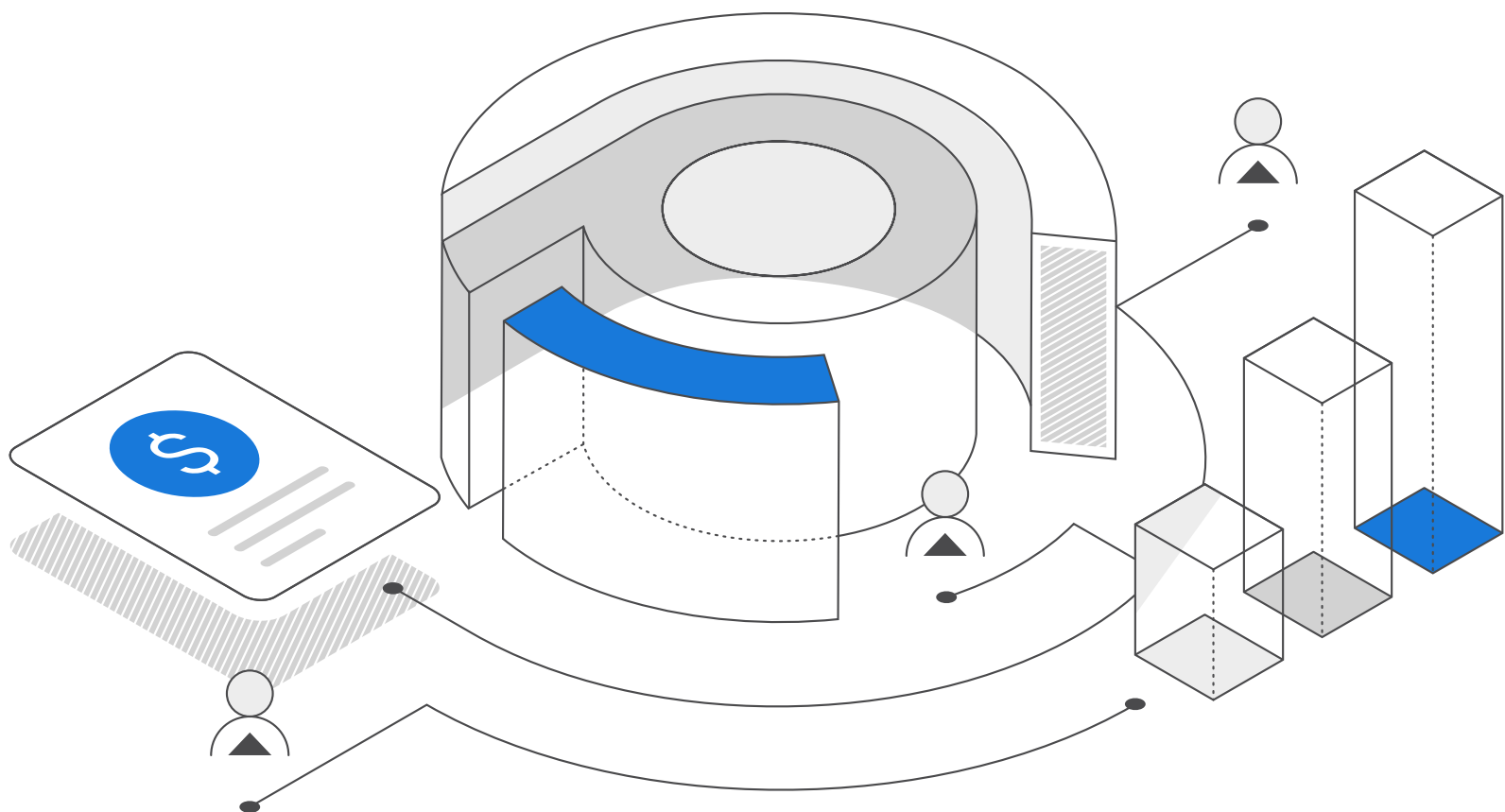

Conflow Power Group Private Overview 2023

This document was sent to you by
Visit listing.ilocx.com/CFP to participate



Conflow Power Overview

CONFIDENTIAL

SELECTED PARTICIPANTS ONLY

You may not forward this document without written permission from
Conflow Power Group Limited (CPG) - presale@conflowpower.com

Conflow Power Revenue Backed License

ROYALTY TO BE PAID DYNAMICALLY AS MONEY IS MADE
10% ROYALTY ON GROSS REVENUE

Licences Issued

3,300,000

Royalty Rate

10% of all revenue generated by CPG, divided
evenly between all holders

Royalty Yield CY23

30% (see royalty calculation)

Current Allocation

1,100,000

Minimum

None

Maximum

10,000

List of Content

1. Overview

1.1 Global Aggregator	06
1.2 Existing infrastructure is inefficient and expensive and it's going to change	07
1.3 Achievements	08
1.4 Worldwide expansion	09
1.5 Radical Scaling	10
1.6 Launch of iCX	10
1.7 Launch of our control centre dashboard	11
1.8 Expansion of our supported energy resources to include	13

2. Defining The Opportunity

2.1 Existing Infrastructure is Inefficient, Unreliable and Expensive	15
2.2 Streetlighting	17
2.3 Energy Generation	19
2.4 Metering and Payments	19

List of Content

3. Conflow – Poised To Take Advantage Of The Energy To Power Transition	
3.1 Multiple Competitive Advantages Position	21
Conflow As The Autonomous Power Leader	
3.2 Conflow – Aggregates best in class technology - Powered by renewable energy - Without grid power	24
3.3 Conflow – The Business Model Leader	25
3.4 Establishing a Presence in Key End Markets	28
3.5 Best-In-Class Management Team and Flawless Execution	30
4. Partners And Projects	32
5. Fundamental & Valuation Analysis	
5.1 Entity Progression and Sales Model	35
5.2 Mechanics of the ILO token	35
5.3 Conflow Power is An IP Play With Lean Operating Structure	36
5.4 Topline Growth Set to Accelerate	37
5.5 Valuation and ILO Listing	38



List of Content

Recent Company News	39
Risks	40
Notes	40

1. Overview

1.1 | Global Aggregator

Conflow Power Group (CPG) is proving that on a small scale, decentralised, autonomous power is more reliable, convenient and efficient than power station and grid-based applications.

It is the start of a major shift.

CPG has aggregated an adaptable set of complementary technologies that together connect, monitor and manage the smart developments, communities and cities of the future.

Our flagship product, iLamp, (www.iLamp.com) combines self-powered smart street lighting, communications, sensors and the essential energy hub that makes communities safer, more efficient and energy independent.

Our technologies:

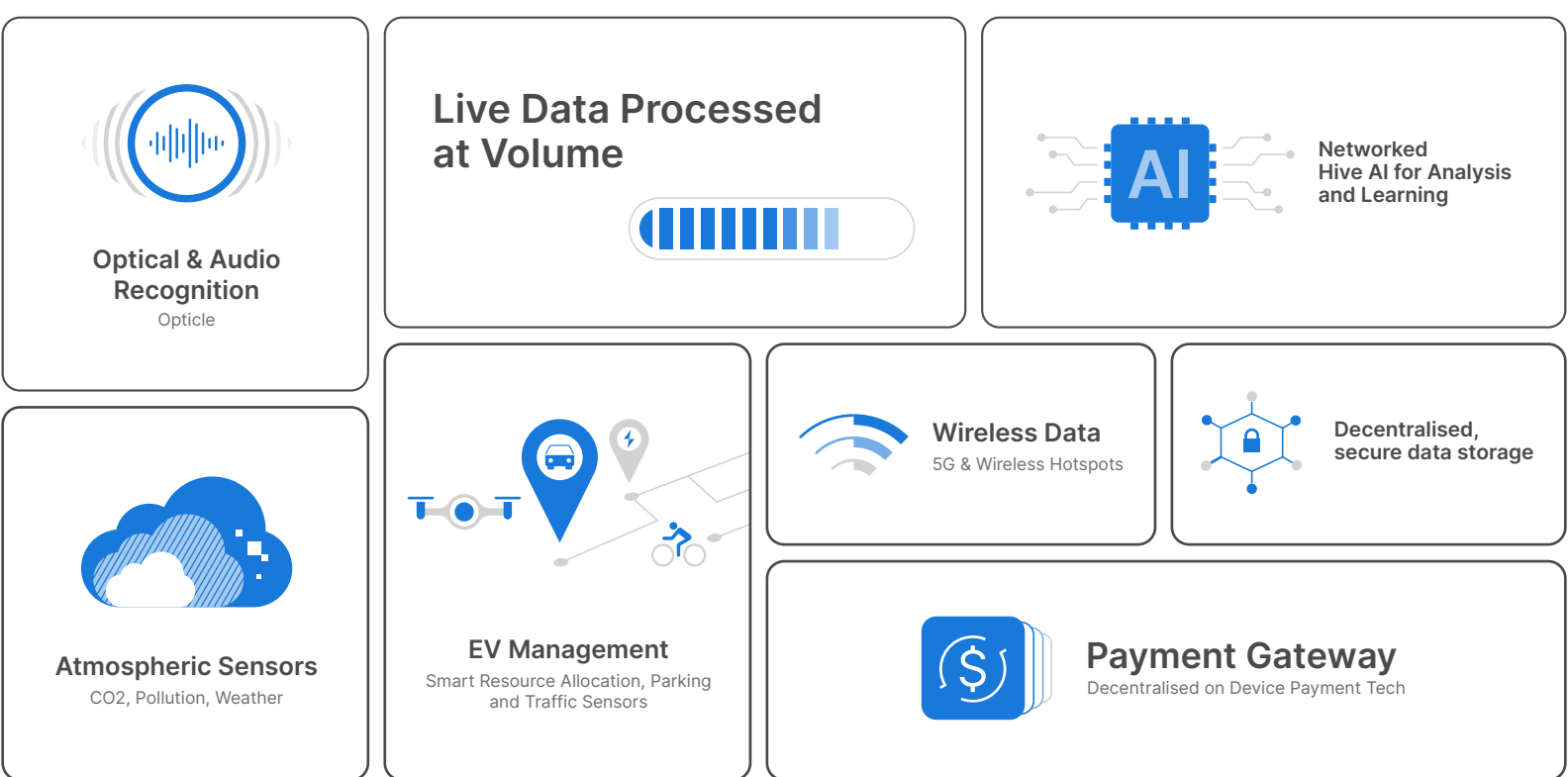

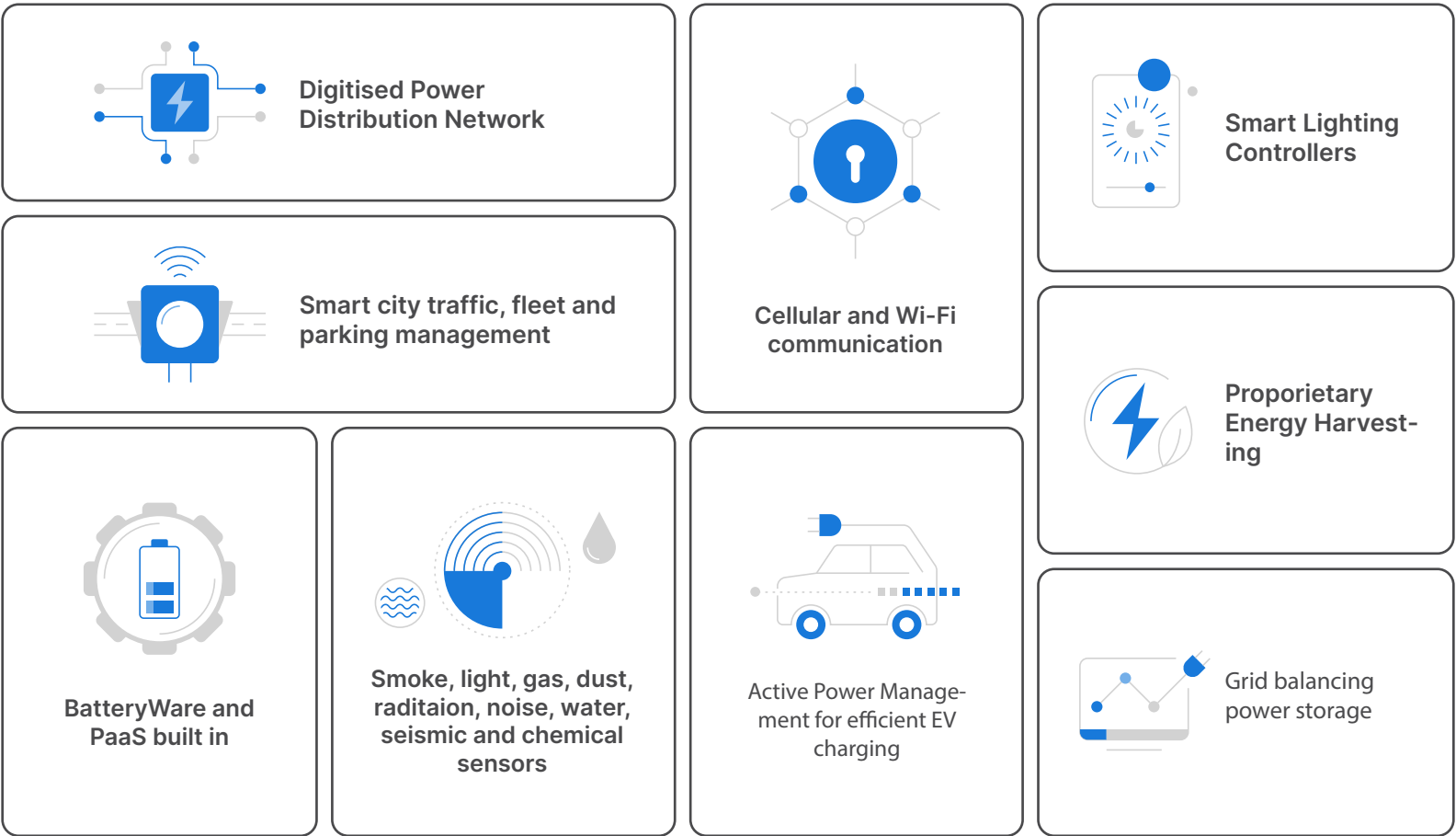

1.2 | Existing infrastructure is inefficient and expensive and it's going to change

Worldwide electrical grids and municipal infrastructure are no longer fit for purpose, running at significant losses and costing more each year to maintain. Change is coming and CPG is positioned to be one of the change makers. Energy grids, outdoor lighting solutions and safety infrastructure such as traffic systems are among the most significant and expensive infrastructure assets owned by municipalities and utilities worldwide.

Energy grids are reaching their end of life, and are not able to manage the distributed nature and second by second, watt by watt operations requirements of renewable energy.

Streetlights consume a large percentage of a city's energy needs, which differs from city to city, but can be as much as 50% of a city's total energy budget, adding LED is only a tiny part of the solution

iLamp is a total solution for street lighting, delivering 80% cost savings, a range of sensors to boost public safety and health, while acting as a modular hub to connect, monitor, and trade distributed energy resources, creating renewable focused microgrids and markets that offer same service, at a lower cost with a host of spinoff benefits.

1.3 | Achievements

Since inception CPG has raised significant resources in order to establish the eco system now in place:

- CPG has sold over 1.1 million ILO units and paid two royalties
- CPG has made a series of key and strategic acquisitions to bolster up the main components of its model
- CPG has signed multiple Joint ventures and technology development agreements with other power tech focused companies to deliver an aggregated approach
- CPG has a development and mass manufacturing arm in Taiwan.



This also serves to develop new components as well as the existing production of light emitting diode epitaxy wafers, using Liquid Phase Epitaxy technology and mass production of AlGaAs Red colour epitaxy wafers and MOVPE epitaxy technology for AlInGaP visible and infrared epitaxial wafers and GaAs Ingot/substrate used for iLamps WIFI and 5G communication applications.

Conflow Power leverages worldwide partnerships and agreements to rapidly scale and roll out globally sourced and designed, locally made power and technology solutions.

CPG has sold 14 territories totalling 1,103,357,483 in population, generating \$100,000,000+ in deferred revenue. CPG is now focused on pre-licensing agreements to layer in the global footprint and slow down the bottleneck from



our global partners. When pre-licensing agreements are signed they are featured on the CPG website and in some cases a public announcement is made, the pre-license holder has work to do locally, preparing the ground for them to hit the ground running as soon as they become a formal licence holder.

As soon as they become full licence holders they must pay the licence fee and in turn CPG pays a royalty to all license holders; this is one of our many revenue streams.

1.4 | Worldwide expansion



The following countries are in the pre-licensing stage, expected to conclude within the next 18 months:

- South Korea
- Ivory Coast
- Benin republic
- Sierra Leone
- Liberia
- UAE
- Nigeria
- Mexico
- Spain
- Australia
- Germany
- Ghana
- Cameroon

1.5 | Radical Scaling

The strategy to radically scale a local footprint is managed by the partnership with ILOCX, the structure that has been created sets pricing for country-based territorial licences based on a mixture of population, cost per kilowatt hour and local infrastructure. The internal team conducts its first research on a country and establishes the primary action points to get that territory up and running as fast as possible. The licensor signs a pre-license with CPC which secures them the rights subject to the action points. CPG has to also allocate some manufacturing capacity and while these activities take place, further research and outreach to local partners and collaborators are set in motion. Once complete they can sign the full licence agreement and hit the ground running. They can also use this time to raise capital and establish partnerships and set up local manufacturing for the non essential components. Example research reports can be found on the CPG website.

1.6 | Launch of iCX

A decentralised technology platform that sets out to transform the global energy marketplace utilising the power of the blockchain to provide a payment rail for investors, project developers, service providers, governments, utility companies, and others all driven from a trusted and transparent platform. The solution also allows for the any member of the global population to gain identity and reputation through transacting on the platform for the most basic of needs – electricity.

Project pipeline spans across 13 countries.



1.7 | Launch of our control centre dashboard

The iLamp dashboard manages all aspects of the network, enabling operators to maximize the value of distributed energy resources (DERs). It is designed to provide a reliable interface that bridges the gaps between all levels of stakeholders.



iLamp Revenue Overview

CO₂ 820 • 42 • 28°C, Cloudy

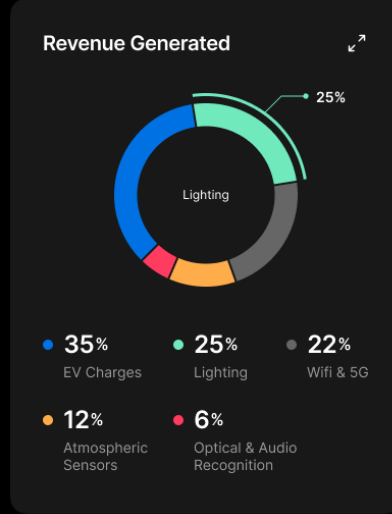
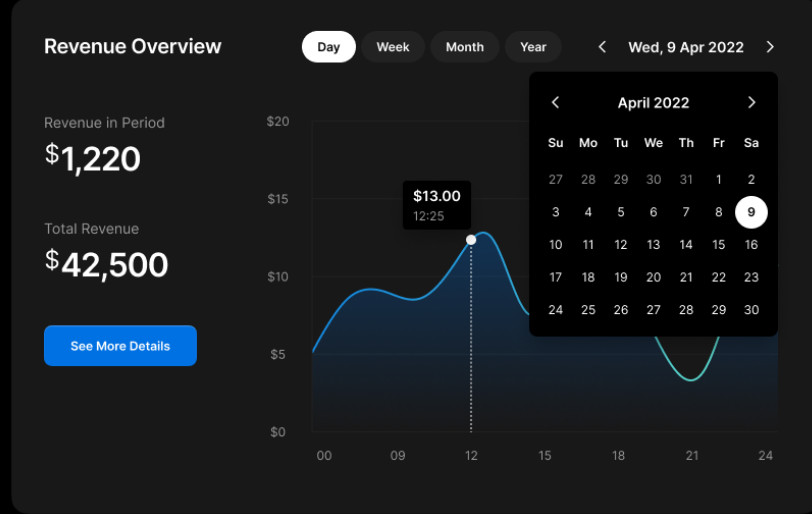

50 Lamps

3 Reports

- Lamp #24** (10/04/2022 17:20): This lamp has reported an incident. Click to view its status.
- Lamp #5** (10/04/2022 15:10): This lamp has been fixed. Click to view its status.
- Lamp #8** (10/04/2022 13:54): This lamp has reported a safety incident. Click to view its status.

56% Capacity | 100% Battery Health | 98% Energy Gain | Active Parking

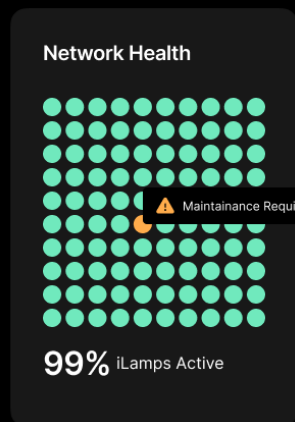
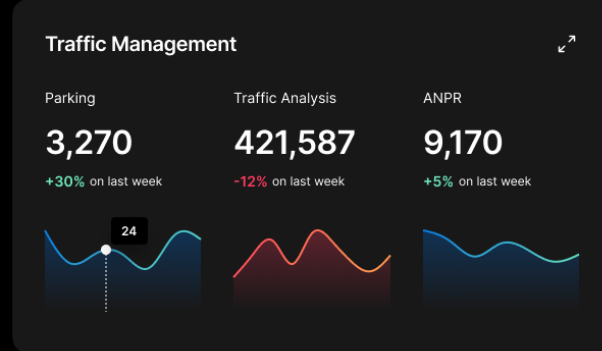
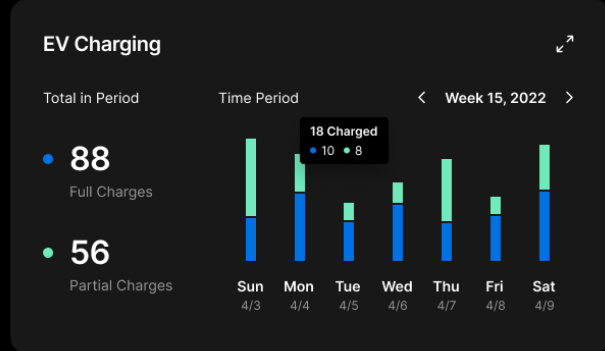

Payment Summary

Invoice	Customers	From	Price	Status
10020	0×11e1918c6b07e...eb71e	UK, London	ICX 0.22	Success
10019	0×11hv12vx12763...88asdf	US, Los Angeles	ICX 1.02	Success
10018	0×8y737btx6364...00mvm	Japan, Tokyo	ICX 4.29	In Progress
10017	0×mczv8bvuuvcx...33nvc	Spain, Madrid	ICX 0.51	Hold
10016	0×1b4h1g24c41j...vcv9c	Canada, Toronto	ICX 0.84	Failed

1.8 | Expansion of our supported energy resources to include:

- A first-of-its-kind, integrated, hybrid energy solution that is being marketed and sold to a worldwide customer base. The system is designed to generate power at the lowest possible cost and can provide energy generation 24 hours/day, 365 days/year. The technology stack is aggregated across multiple partners and these are patented globally. The product is based on a modular, scalable, distributed renewable energy system designed and optimised for on-grid and off grid installations. The relationship allows CPG to increase its penetration into emerging markets with a high contribution to the reduction of fossil fuel use and access to renewable energy credits.
- One of the Patent approved technologies CPG employs is leveraging decades of power generation experience to create a new method of electrical production. By eliminating the majority of moving parts, it is creating an efficient generator (10kW) with significantly lower CAPEX and OPEX. At the same time, it removes the need for input such as fossil fuels, helping power generation needs while addressing climate issues.
- Next generation energy storage for lithium-ion batteries. Will create a unique chip-based rechargeable battery technology, whose performance is exponentially more efficient than any other lithium battery. There are numerous Patented Technologies, and additional Patents Pending within the stack, and several years of development with investment and grants from public and private entities, this solution enables scalable, high-volume manufacturing at the industry's lowest cost, by using existing manufacturing and contract assembly techniques.
- Science-to-commercialization by creating unique Energy Harvesting (EH). Energy Harvesting Circuits or (EHCs) produce minute levels of power. When embedded on a chip in arrays, they can work together to produce higher levels of power output. These low-power energy harvesting chips will be used on all Conflow circuit boards.
- Conflow is developing the iCharge sector to lead the way in using renewables for the EV market place. There are already numerous reports in the press where large percentage of EV charging stations are not working, some as high as 50% of the EV stations are unavailable when customers need them, this is due to poor quality equipment, low level and unprofessional installation and lack of maintenance. Conflow will launch its

iCharge Network in due course and is teaming up with a major player in the sector that has high standards numerous installations and is growing at a fast pace in the regular grid based systems, adding the iCharge off grid versions will make headlines.

Conflow Power Group continues to show its innovative nature in both developed and emerging markets. The ability to develop and test new technology while generating revenue proves to be an impressive answer for the alternative energy solutions Conflow is aggregating.

Conflow is piloting one of its streetlights in California . In preparation for its first contract of off-grid streetlights to Conflow Power USA. This testing is prior to a mass roll out supported by and in partnership with Southern California Edison (SCE) and homebuilder S2A Modular who will provide an iLamp to each house in their pipeline of over 300,000 homes.

In the traffic light division Conflow is launching iTraffic, CPG is in detailed and lengthy negotiations with the state of California to provide a pilot installation in early 2024.

2. Defining The Opportunity

2.1 | Existing Infrastructure is Inefficient, Unreliable and Expensive

Most established centralised electricity grids were built in the 1960's to transport energy one way, from large power plants, to end users. These grids had an expected lifespan of 50 years. Today, solar power represents the cheapest energy in human history and centralised electricity grids worldwide find themselves without sufficient flexibility to operate efficiently, unable to match supply to demand in real time and in many cases unable to cope. The US grid alone requires annual maintenance of \$156 billion, while blackouts in the US increased by a staggering 73%. Worldwide transmission and distribution losses total over 13 trillion kWh each year. These inefficiencies are not widely reported but are a significant factor in the now apparent energy crisis.

Fewer than a quarter of proposed clean energy projects make it to commercial operation because of transmission hurdles.

[World Energy Balances: Overview – Analysis - IEA](#)

[Electric power transmission and distribution losses \(% of output\) | Data](#)

<https://www.washingtonpost.com/business/2021/06/29/power-grid-problems/>

The grid is also vulnerable to solar storms, increasing extreme weather and natural disasters as well as physical and cyber attacks.

Blackouts affects our health, environment and quality of life, preventing sewage treatment, causing raw sewage to be pumped directly into water bodies. Stopping drinking water filtering and pumping leading to contaminated water or supply issues. Even hospitals are still underprepared and can only keep essential equipment with external assistance.

<https://www.nytimes.com/1972/07/19/archives/hospitals-appear-unprepared-for-blackouts-despite-failures.html>

Going forward, we can either build the grid back the same way we've done before or we can invest in new technologies that can bring the same service but at a lower cost.

Replacing these systems in the shift to clean energy represents the largest commercial opportunity of our time.

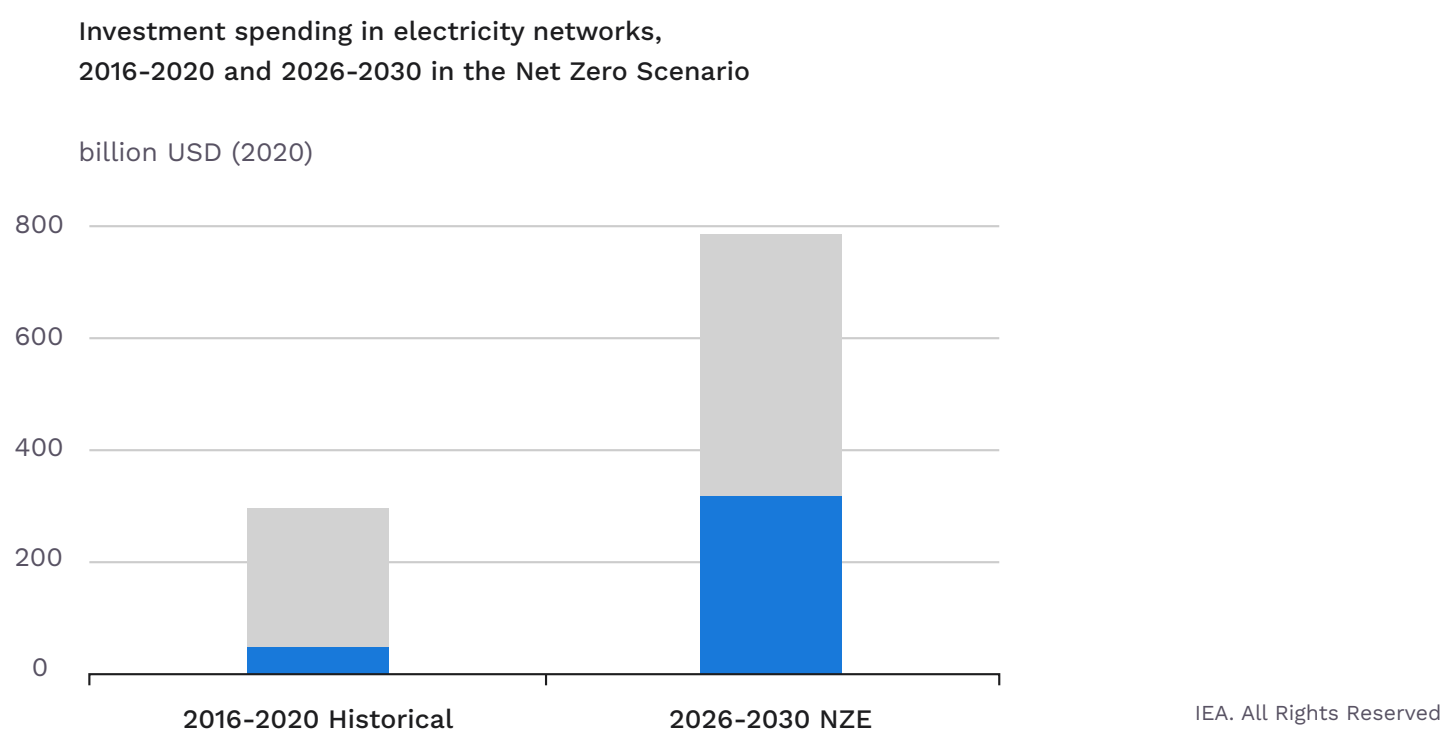

Centralised:

- High environmental impact
- High cost to customer as power companies struggle with efficient power generation, accurate billing and metering

Energy is unstable, with war and supply issues reverberating from COVID exacerbating the energy instability of certain countries, driving price per kWh to all time highs.

2.2 | Street Lighting

Existing street lighting infrastructure is creating the need for smart street lighting solutions. Outdoor lighting solutions are among the most significant and expensive infrastructure assets owned by municipalities and utilities. They often consume up to half of a city's total energy budget. According to Arthur D Little, there are ~320 million street light poles worldwide, led by Asia that accounts for 25% of the global total, and followed Europe and North America with 20% share each and South America with 10% of the global total. However, the existing lighting infrastructure has multiple limitations and shortcomings which include:

- Outright cost centres as existing lighting infrastructure can consume 40%-50% of a city's energy budget
- Short life expectancy and high failure rates as a typical streetlight last no more than 20,000 hours
- Untapped space between poles leading to loss of revenue generating potential
- High energy inefficiency and consumption rates leading to high running costs and environmental (ESG) impact
- Difficult maintenance and location of faulty units that often rely on requests for repair from local citizens
- Unmetered, imprecise billing that results in unmetered load estimates

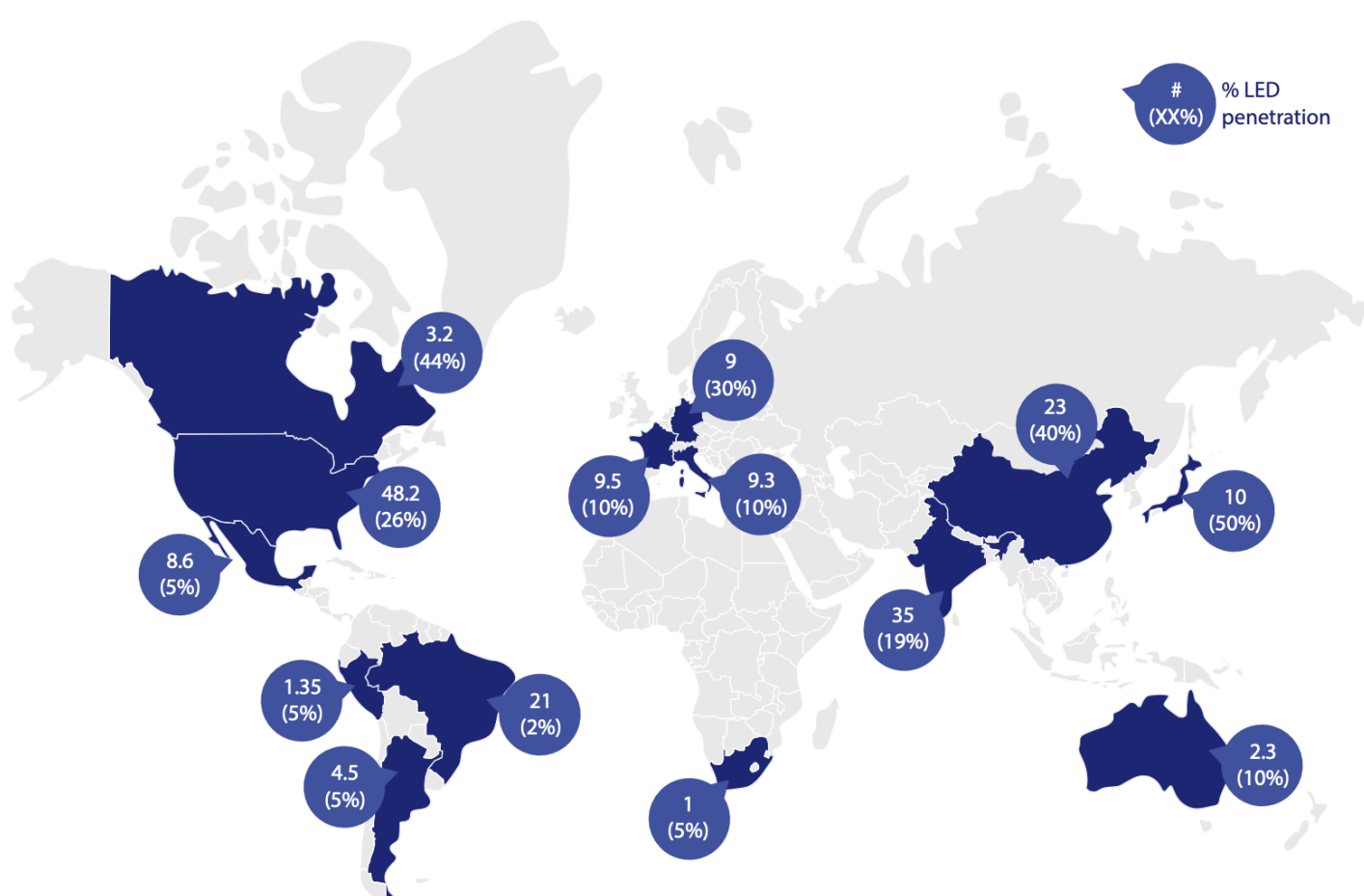

According to Mordor Intelligence, a growing number of smart city initiatives and adoption of platform-as-a-service solutions are expected to drive the growth of the smart street lighting ecosystem.

- Smart cities. The increasing number of people living in urban areas, 81% of the total population, is one of the major drivers for the adoption of smart and intelligent solutions.
- Public lighting infrastructure has three key features that position itself as potential strategic assets for smart cities' concept, enabling the development of a common platform with significant cost synergies: capillarity, electrification, and connectivity.
- Power-as-a-Service solutions are also being adopted for streetlights. These solutions provide a hub for technology hosting including - centralized monitoring, simplified control, and real-time alerts for smart city applications, without worrying about designing, building, or maintaining a citywide communication network. There are several cases where connected street light solutions have been deployed successfully. For instance, Telensa Ltd has partnered with Australia's government to implement its PLANet intelligent street lighting system in Darwin, Australia. Darwin is reducing energy and maintenance costs, improving the quality of service through automatic fault reporting, and the use of streetlight poles for supporting hubs for smart city sensors, but they don't go as far in terms of technical application as iLamp does.

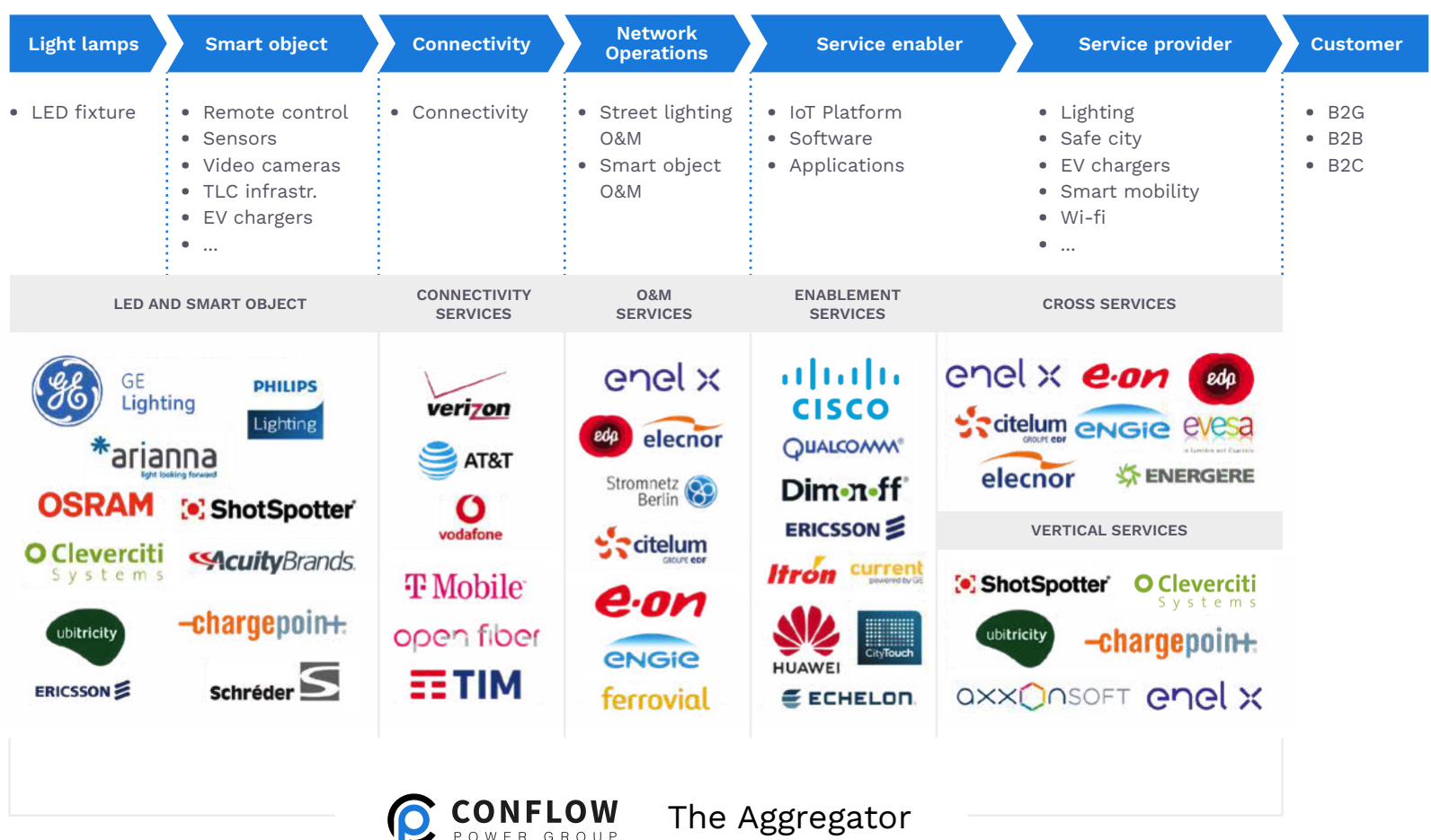

2.3 | Energy Generation

Conflow Power can establish complete energy systems that create micro grids that eventually can link together making a near global grid, sharing data, power, communications, economies of scale and a fully autonomous structure from the street furniture itself to the power generation and with iCX the economy that runs it all, this will include iLamp, iCharge, iTraffic, iStopSign and more.

CPG is going broad on its base of sectors, worldwide via its licensing model and across all economies with iCX providing the decentralised currency to transact it all. The partnerships CPG has already forged will ensure that within these sectors collectively these components will be generating millions of hours of autonomous power and therefore in turn minting millions of iCX tokens to facilitate trade, investment and opportunity for all stakeholders. Power generation is coming into the hands of the masses in a cleaner more efficient and decentralised fashion.

2.4 | Metering and Payments

iLamp creates significant economic and social benefits and opportunities, providing cheaper energy prices, increased energy security and mitigating the risk of blackouts. iLamp uses smart metering from Power-As-A-Service modules, combined with the blockchain to process payments efficiently, allowing anyone to accurately buy or sell energy in any quantity, keeping money and infrastructure local, decreasing grid dependence.

iLamp is able to accurately metre and charge for power generated and distributed as a combined on/off grid utility asset, which improves efficiencies while maintaining profit levels for the local power companies. Especially when the grid is strained. This opportunity lessens the draw on the grid, so electrification (i.e. EV charging) can expand without infrastructure challenges.

iCX is a payments framework and open sourced hardware/software bridge aiming to localise, decentralise and individualise power. Our package will enable off grid and autonomously generated energy to be sold accurately, reliably and fairly.

Energy providers will be able to immediately monetize their power at any scale,

without any charges or mark-ups, while energy buyers will benefit from low cost and easy to use power.

iCX leverages enhancements in power generation, storage, delivery and payment infrastructure to provide a more efficient, accurate and cost effective alternative to traditional energy.

Through Conflow Power, iCX has access to the latest solar, generator, turbine, sensor and battery technology, packaged and linked through iLamp to enable the generation and distribution of power at significantly less than the global mean average, while creating functional, autonomous microgrids that effectively distribute power to where it's needed.

iCX then leverages the blockchain to increase the trustworthiness, integrity, and resilience of energy delivery systems, enabling transactions to be recorded and settled almost instantly, with no need for an intermediary and with little or no need for reconciliation since all parties are using the same platform. What's more, a blockchain entry can include executable computer code that reflects the terms of the contract—creating a smart contract that automatically validates transactions without the need for humans. The P2P energy trading with the help of the blockchain can eliminate inefficiencies such as transmission line losses, congestion, and volatile price formation.

The iCX merges innovation with consensus and adds to the need for value with Blockchain verification coupled to a beating heart of hard core commerce. Both smart contract adoption and customer use cases are reported on the same ledger to effect change in cities around the world that reflect perfectly the change in financial instruments around the world.

Digital assets controlling and reporting on assets that are both physical and which generate masses of further digital assets in the form of data and intelligence, independence and security, light and power, connectivity and commerce. For the very first time in history these elements are colliding to allow any human being on the planet to have a stake in smart cities and all they evolve one iLamp at a time.

Writing logic within a few lines of code can work for smart contracts yet Conflow Power has had to affect a series of key relationships to create a business model that can incorporate a new currency in the form of the iCX and couple it with physical products and contracts to manufacture and sell a much-needed innovation within our global street furniture that is as innovative as the Bitcoin and Ethereum.

3. Conflow – Poised To Take Advantage Of The Energy To Power Transition

3.1 | Multiple Competitive Advantages Position Conflow As The Autonomous Power Leader

iLamp creates intelligent, autonomous and ever evolving technology and power networks; for the first time ever bringing minute by minute, watt by watt and cell by cell monitoring, analysis and control to deliver accuracy and fairness.

Together iLamp, PaaS and BatteryWare autonomously manage and optimize resources and, critically, enables a modular microgrid – one where assets and distributed energy resources (DERs) can be added or removed seamlessly.

Using BatteryWare machine learning and AI systems can react to environmental conditions to create self healing microgrids that are constantly adapting to optimise efficiency.

Power as a Service brings transparency through all systems, so that metering is truly smart and truly accurate.

In addition to providing a turn-key, reliable, self sufficient alternative to grid power, iLamp will integrate critical safety systems, which are currently unlinked, unreliable and expensive to maintain, from sewer gas sensors, pollution and air quality monitoring, to cctv and traffic systems, iLamp can link, manage and synchronise these systems, providing a real time holistic picture of the city. iLamp can equally be leveraged in remote environments to provide early warning fire directions leveraging sensor modules, act as a communication gateway leveraging 5g and wifi modules, and enable critical deliveries leveraging drone landing and guidance modules via Drone Ready.

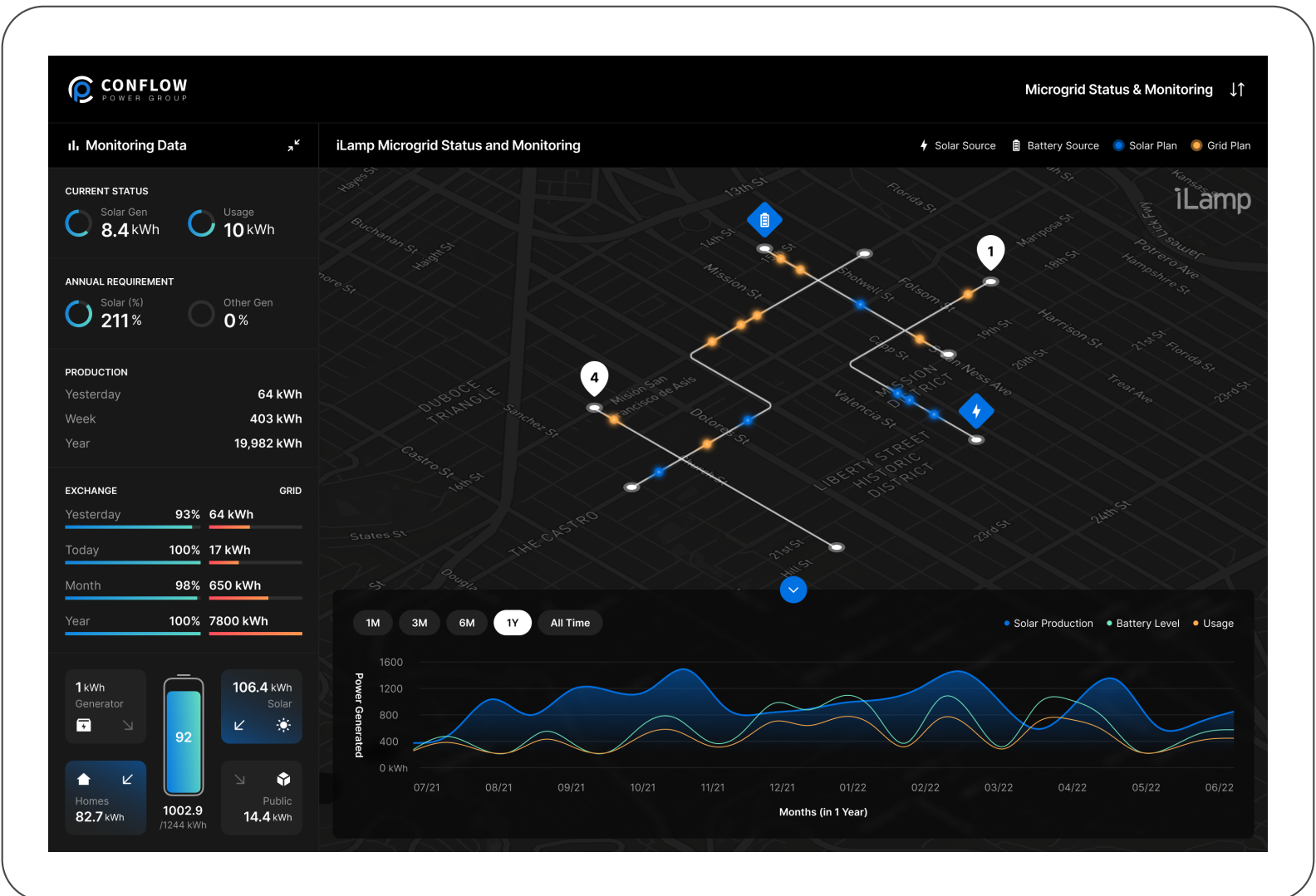

Within the smart street lighting market, the smart pole segment – Conflow’s first focus area – will play a key role in modernizing city infrastructure which is expected to generate \$15.7 billion in revenue by 2023. Navigant Research defines smart poles as the integration of smart lighting systems, sensors, wireless connectivity (Wi-Fi and cellular technology), and other functions into one cohesive unit. Equipped with smart video cameras and sensors, smart poles are particularly helpful in decreasing the traffic and overcrowding, which lets the drivers drive easily and carefully on the roads. It also acts as an emergency communication element with announcement speakers and digital signage. Remotely managed smart poles house technology to improve mobile network with 5G performance across the grid. They are also considered to be digital real estate of the Internet of Things (IoT). Having a multitude of remote management functions on a single pole will reduce maintenance costs and will help cities to be more energy sustainable.

These multifunctional poles create space and improve the environment visually and operationally. From a sustainability point of view, smart poles are 100% recyclable and operate with renewable energy. Driven by these advantages, the use of smart poles is growing around the world and this segment is expected to grow at a CAGR of 12.9% till 2030 when it will be worth \$19B, according to Research Reports World. Many cities around the world – especially in Europe,

the U.S. and Middle East – have run Smart Pole pilot projects. These pilots have proven to be successful, allowing for smart pole adoption to rise extremely fast and surpass industry estimates. In order to scale they will need manufacturing capability which in the current supply chain environment will be a major barrier. Conflow has the mass manufacturing to facilitate a global rush to smart city infrastructure.

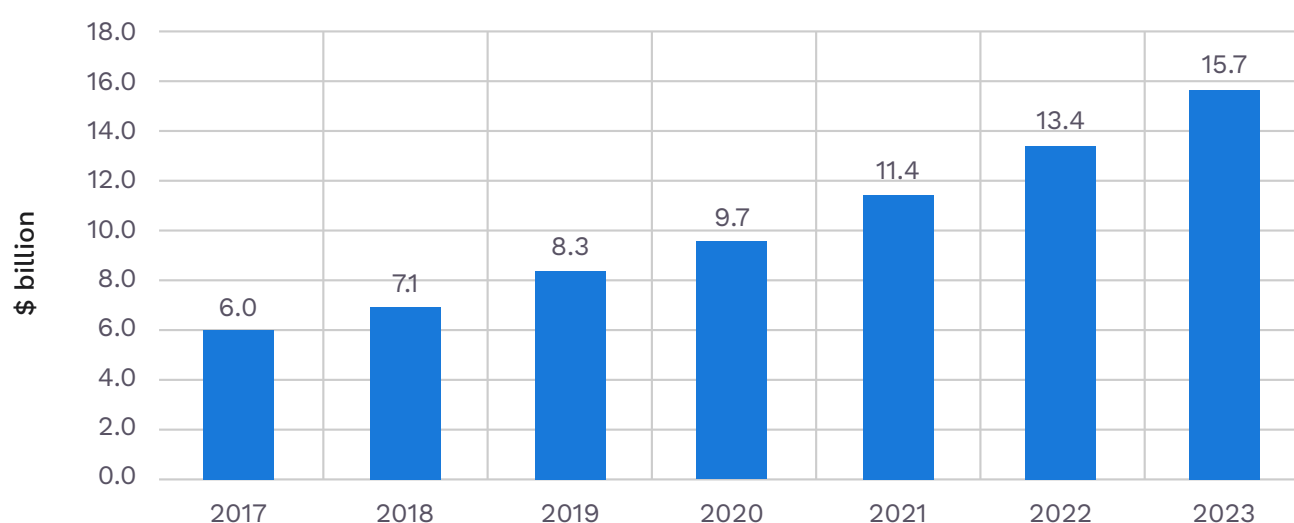

The Global Smart Pole Market Is Expected to Grow at 17% CAGR to \$15.8 billion by 2023

Source: Intro-act, Genesis Market Insights

Conflow is primed to emerge as a smart city platform leader due to the multiple competitive advantages. According to a report by advisory firm Navigant Research on Smart streetlights, Signify, Itron, and Telensa are currently the leading companies for smart street lighting, based on value, market strategy, product strategy, sales, marketing and distribution, product features and portfolio, and product integration. Also, Echelon, Rongwen, and Current, powered by GE are innovative contributors to significant city developments.

However, Conflow is all set to disrupt this competitive landscape and emerge as a leader due to the following five competitive advantages enjoyed by the company:

1. Technology innovation and aggregation
2. Business model leadership
3. Presence in key and large end markets
4. Best-in-class management team
5. Scalability
6. Components, services and tech stack not even contemplated by large corporations

We simply leave others behind as we have ensured production tech structure, finance and strategy.

ConFlow's Competitive Advantages

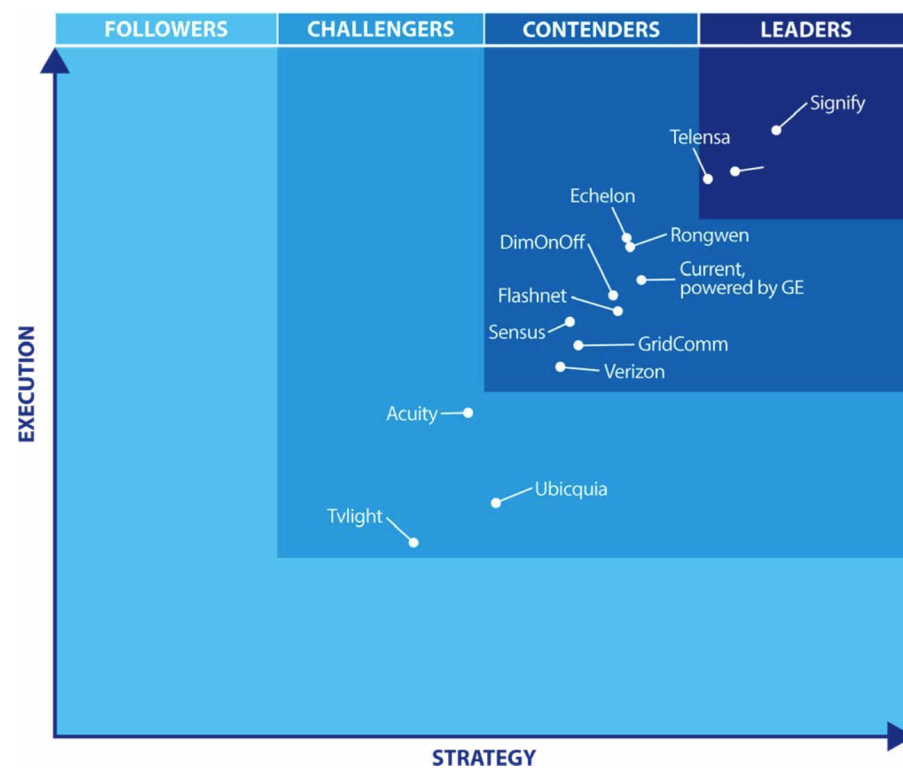

3.2 | Conflow – Aggregates best in class technology - Powered by renewable energy - Without grid power

The Conflow Power Group is a technology innovator and aggregator. Conflow has created an adaptable set of complementary technologies, including proprietary innovations, licensed technologies, and joint venture project developments. The first result of this is the smartest of smart lighting products. The streetlight, now fully developed by Conflow, delivers a diverse range of technologies within a single device. This innovation turns what is traditionally an outgoing cost into a source of profit while delivering a range of valuable safety, public and health services. The company has redesigned and re-evaluated the concept of what a streetlight is – once considered an unavoidable cost, now reinvented as a profit center.

ConFlow Lighting - Built for Smart Cities

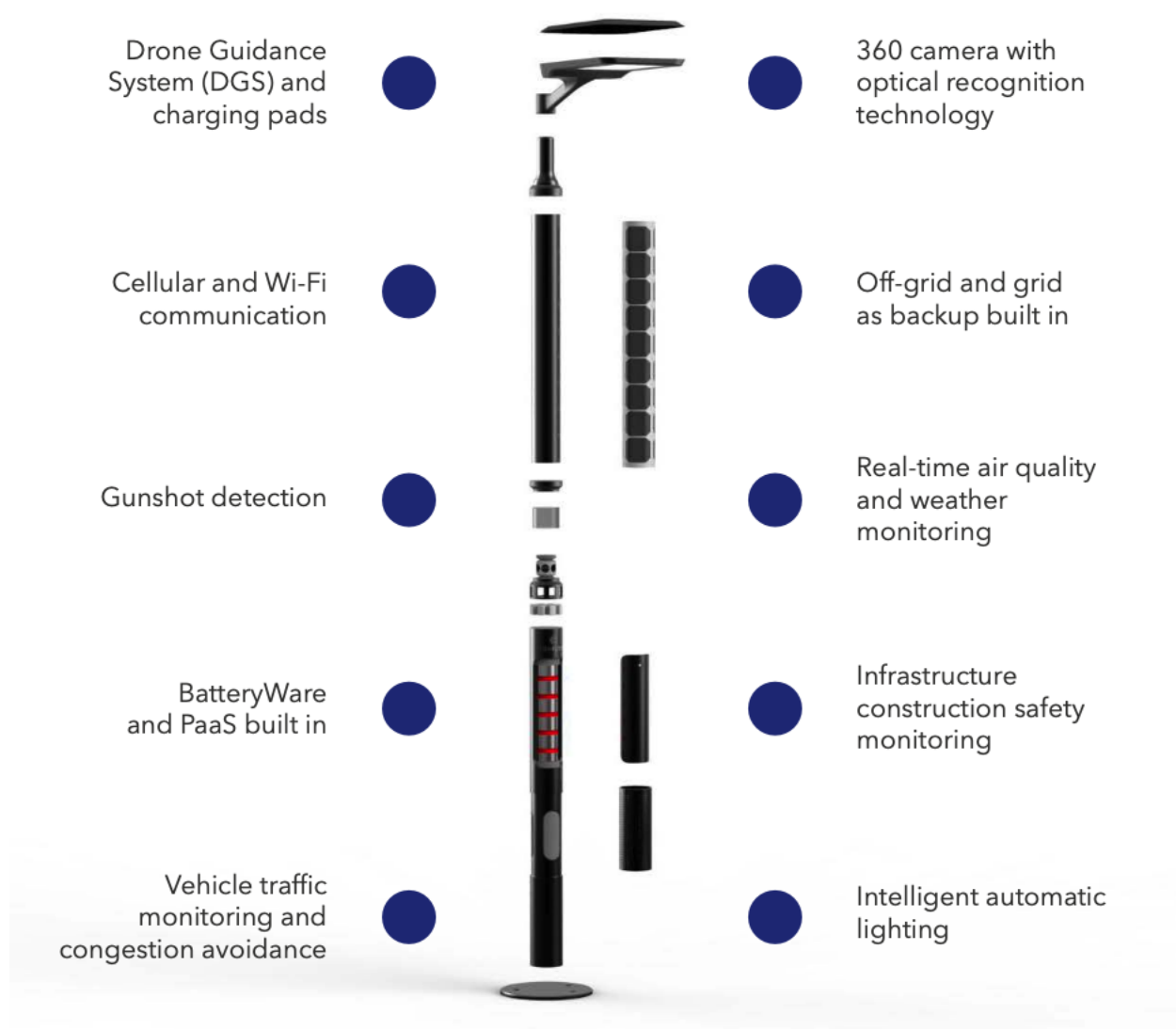

3.3 | Conflow – The Business Model Leader

Conflow Power has partnered with Power As A Service (PaaS) to create recurring revenue from its entire product range. At the point of recharge, the PaaS technology will charge the user for the top up. It is for this reason Conflow only develops products where communication to the device is possible and not cumbersome. PaaS' technology can be used for the following purposes:

- **Smart monitoring:** In collaboration with BatteryWare (owned 100% by Conflow), Power As A Service (PaaS) uses cutting-edge smart monitoring technology to track live energy consumption. It alerts users to any problems and can suggest and implement energy saving changes. BatteryWare's smart IoT sensor, SensorWare, can be retrofitted to any existing power system. Installation is only required in one outlet per circuit, which then feeds data to be analyzed in real-time by BatteryWare's adaptable AI. This allows PaaS to isolate any inefficiency in the power system and provide suggestions on how to remedy it.

- **Exact charges:** The PaaS payment gateway is currently at work in several off-grid energy projects, delivering continuous green power in locations and scenarios previously too expensive or impractical to consider. From a user perspective, paying for the energy used is a very simple and straightforward arrangement, but for the power industry it is revolutionary. The PaaS advanced payment gateway allows for flexible payments to suit the user. By analyzing live data on real-time usage, then providing users with predictions and suggestions, this allows users to actively manage and minimize their power usage.
- **Precise billing:** Inaccurate bills are the number one complaint from customers of existing energy companies. Existing power companies overcharge their customers on a regular basis, backdating bills, and using money from accounts in credit. PaaS technology integrates directly with the power source, meaning the energy supplied is the energy billed, thus eliminating any room for discrepancies and estimates.

The partnership with PaaS opens multiple large addressable market for Conflow. The biggest four are listed below:

- **Electric vehicles:** Power as a Service enables battery-operated vehicles to be charged without huge investments in power stations. This vastly increases their viability in terms of as many locations as possible, as few countries currently can afford to have nationwide charging stations. It also expands the range and viability of delivery drones.
- **Smart grid technology:** Excess stored power can be deployed when grid power is out, as a means for emergency backup power. Further increasing the ILO royalty potential.
- **Intelligent public infrastructure:** PaaS enables self-powered public infrastructure such as Conflow's Smart Streetlight project. These will bring cities into the future with integrated delivery drone docks, automatic light monitoring and adjustment, in addition to public safety features. All powered by renewable energy sources.
- **Residential power supply:** PaaS can be used to deliver power to residential accommodation, such as apartment blocks, at a fraction of the current cost. Thanks to the monitoring and analysis technology provided by BatteryWare, the power used by each resident can be accurately tracked by the PaaS system.

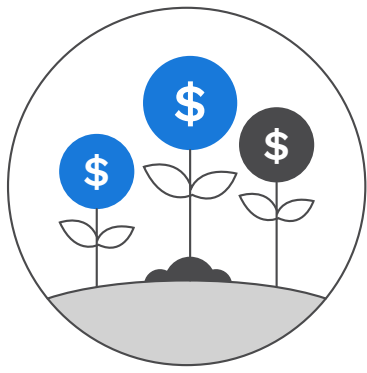

Low Energy Costs

PaaS changes users less per kilowatt-hour than through local rates. This price is guaranteed for the next 25 years after provision of the technology.



Off-Grid Locations

PaaS eliminates the need to construct major power infrastructure in remote locations. This enables energy generation anywhere, even in locations without reliable internet connections.

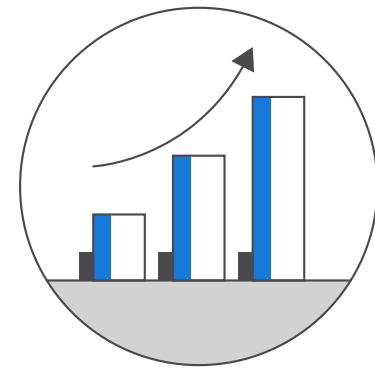

Highly Scalable

PaaS allows users to only pay for the energy they actually consume. Organisation can easily scale up as they grow, which lowers the risk and barrier to entry for new business and projects.

The second key part of Conflow's business model is its ownership of BatteryWare Limited as this technology allows Conflow to ensure it can manage and monitor all devices and power top ups. This allows for an extraordinary amount of data to flow from the target device to Conflow's data hub. All aspects of the on-board power sources are monitored constantly. If a device fails, that failure can be spotted ahead of time and replacements can be deployed. **A continuous flow** of power is at the core of Conflow's ethos - reliable off-grid power (with the grid as a backup).

BatteryWare owns significant Intellectual Property (IP) for Battery Testing, Data Transmission and Results Analysis. In development since 2011, BatteryWare technology can be used for the following:

- **Battery Testing:** BatteryWare devices test the key data points of a battery's field performance under load. This data is transmitted back to our lab for detailed analysis. As a result, BatteryWare gives you an in-depth understanding of battery performance, reliability and expected lifespan, with real-time updates on power loss, failures, and recharging events.
- **Optical Recognition:** BatteryWare features advanced optical recognition, with car number plate and privacy-friendly facial recognition built-in. It works with a variety of camera systems, linking with third party providers to provide further functionality such as recognizing architecture, vehicle types, public infrastructure, emergency services and more.

- **Artificial Intelligence:** BatteryWare incorporates artificial intelligence to manage its analysis, as well as hive independent investigation and learning.
- **Safety Testing:** The technology also detects safety issues, tampering, ambient and internal temperature, real- time GPS monitoring, maintenance issues.

The street lights modules include 360 cameras and microphones, and will be able to monitor weather conditions, air quality, ambient lighting, and temperature, and more. All these devices feed directly into BatteryWare, which becomes the controller and database for all this technology. When BatteryWare detects anomalies or changes, units can work together, each testing different solutions to intelligently restore light levels or other system functionality. It only takes one unit to fix the issue and new settings are automatically rolled out to every other streetlight experiencing the same problem. In the future, the lamps will then remember this solution when similar scenarios occur.

3.4 | Establishing a Presence in Key End Markets

Along with smart cities, Conflow Power is building strategic partnerships with selected companies in various industries including transportation, lighting, energy, medical, and communications. These efforts will help expand the company's market presence across industries and geographies boosting market share gains.

Key industries Conflow is targeting are:

- **Medical Electronics:** Conflow technology has a range of potential uses within the field of medical electronics. Conflow can provide reliable power sources that do not rely on grid power, ensuring vital equipment remains operational in the event of a wider power failure, and enabling better health services in remote locations. Patient monitoring data and analysis can be stored securely in the data hub for easy access by other systems. Conflow is looking to team up with medical businesses and technology providers who can complement Conflow's skill set to bring this technology to the medical sector.

- **Lighting:** All the features included in Digital Smart Lights can also be deployed as independent technologies, enabling safer and more cost-efficient lighting both on and off the grid. Intelligent lighting that adjusts to visibility conditions, traffic monitoring, and public safety features such as air quality tracking and gunshot detection are just a few of the unique capabilities offered by smart lighting.
- **Energy:** The Conflow Power Group and its strategic partners have energy at the core of all the technology and projects. Conflow has developed a revolutionary self-generating power source, allowing for reliable provision of power even in off-grid locations. Conflow energy solutions can meet demanding requirements with minimal environmental impact, helping businesses meet their sustainable energy targets. Conflow is dedicated to revolutionizing the sustainable energy industry and is seeking partnerships with energy companies that share the goal of a greener future for power.
- **Communications:** The Conflow Power Group and its strategic partners are currently using telecommunications embedded technology in their lighting poles to act as both masts and transmitters. The Conflow data hub can manage and monitor vast networks of interconnected devices, enabling business to communicate better and fully utilize Internet of Things (IoT) technologies in their projects. Conflow Power's long-term off-grid capability also makes it ideal for powering communications infrastructure such as mobile towers in remote locations, enabling full business communications and IoT deployment outside of urban centers. Conflow is currently working on integrating base stations and masts into Smart Streetlights and is building a network of strong strategic partners in the communications sector.
- **Transportation:** The Conflow Power Group and its strategic partners have already developed numerous transport, navigation, and traffic management systems for inclusion in Digital Smart Light systems. These technologies are available for integration into a diverse range of projects, from public works and transport networks to delivery and logistics uses. These include vehicle and pollution monitoring, and dynamic traffic routing. With more than 100,000 live data points already in the field, this offers a revolution in transport data collection.

3.5 | Best-In-Class Management Team and Flawless Execution

Conflow Power's leadership team and board has the optimal mix of business expertise, technological competence, regulatory, and capital market experience to take the company to the next level. We believe that the combination of the right business expertise and stability lends consistency and continuity in strategy and execution and is key to company growth and revenue generation in the long term.

Conflow's management team and board comprises the following:



Edward Fitzpatrick | Director and Chairman of the Board

Edward was granted a broker's license before the age of 21, which led to a financial career creating instruments such as convertible debentures for investments into US companies, Discounted Bonds, as well as innovative Private Equity and Pre-venture Capital structures. A social entrepreneur and investor, he funded 155 million dollars to establish the first successful oil exploration venture in the Sudan 25 years ago. He moved to Switzerland in 2000 where he founded a number of private equity firms that have invested hundreds of millions of dollars in various businesses, ranging from infrastructure, health care, IT technology, luxury goods and media. He is also the Founder and Chairman of ILOCX.



Joseph Cleveland | Head of Operations

A British national, resident in London, he acquired the diverse mechanical engineering skill set required by the Conflow Power Group, as an employee of Bosch, the German multinational engineering and electronics company. He currently coordinates and oversees the team working on the implementation of Conflow technologies, as well as assisting with the technical management, having previously led the design and development for the integration of BatteryWare and Power as a Service technologies into the Conflow Lighting project, including leading the design and mechanical integration for the lamp retrofitter.



Manfred G von Nostitz | Director

Ex-Canadian Ambassador to Thailand, Malaysia, Pakistan, and Myanmar. As a senior Canadian government official in Ottawa specializing in Intelligence and Asian affairs. Following government service, he has 23 years of business and banking experience in Asia. Resident in Malaysia, he has an Arts and Science Hon. B.A. and M.A. from the University of Toronto. Formerly the VP of Shanghai based Profound Automotive in Southeast Asia and Principal Advisor to the Malaysian Southern Bank Group, he has specialized in corporate acquisitions, trademark protection, technology transfers, investor relations and merger implementation. In Canada he is a Board Director of e-Play Digital, a sports media company. In the U.S. Asia Pacific Director of an agricultural company ONIT Sciences. In Malaysia, he is President of VAG Communications Sdn Bhd and a member of the NEM Foundation specializing in blockchain solutions. In Thailand he is the Advisor to the Industrial conglomerate the PM Group.



Christopher Bonvin | Director

Former Banking Executive with Williams and Glyn's Bank, London The Royal Bank of Scotland, and UBS Banking Group London. Management of back room operations of banks, overseeing Commodity and Currency Spot Traders to ensure the correct processing of multimillion currency and commodity transactions and resolving problems between banks and brokers. He has served as a Director of the Board of E-Getx Ltd and BatteryWare Ltd.

4. Partners And Projects

ConFlow Power Group partners with equipment manufacturers, network owners and operators, utilities and third parties to create microgrid distribution business models that can be operated in scalable real-world conditions.

ILOCX

Initial Licence Offerings (ILOs) are a revenue-based form of raising money. The ILO is a straightforward distribution rights licence that expires after an agreed period of time or is changed for cash under a buy back or for equity dependent on the offering. ILOs can be bought and sold mid-term on the ILO Contract Exchange (ILOCX).

BatteryWare

BatteryWare is a smart, reliable way to monitor battery health and prevent failure. BatteryWare monitors individual cell voltages and temperature in real time, displays these local conditions on an easy-to-read display and alerts if a problem is detected utilizing advanced sensor and communication technology.

PaaS

PaaS uses cutting-edge smart monitoring technology from BatteryWare to track live energy consumption and alerts users to potential failures. PaaS also allows users to actively manage and minimize power usage and integrates directly with the power source, eliminating billing discrepancies.

iCharge

iCharge is a one-stop solution to charging electric vehicles, powered by off grid power generation and connected through dynamic self-organizing smart networks. iCharge offers various products/services ranging from smart charging stations, home charging units and more to support the growing adoption of electric vehicles.



iTurbine

iTurbine is a miniature advanced turbine device designed to be deployed remotely around the globe in response to growing wildfire threats. Combining multiple turbine devices to create a honeycomb structure, iTurbine provides dependable power for critical air sensing technology, which is capable of alerting emergency services in real-time

iTraffic

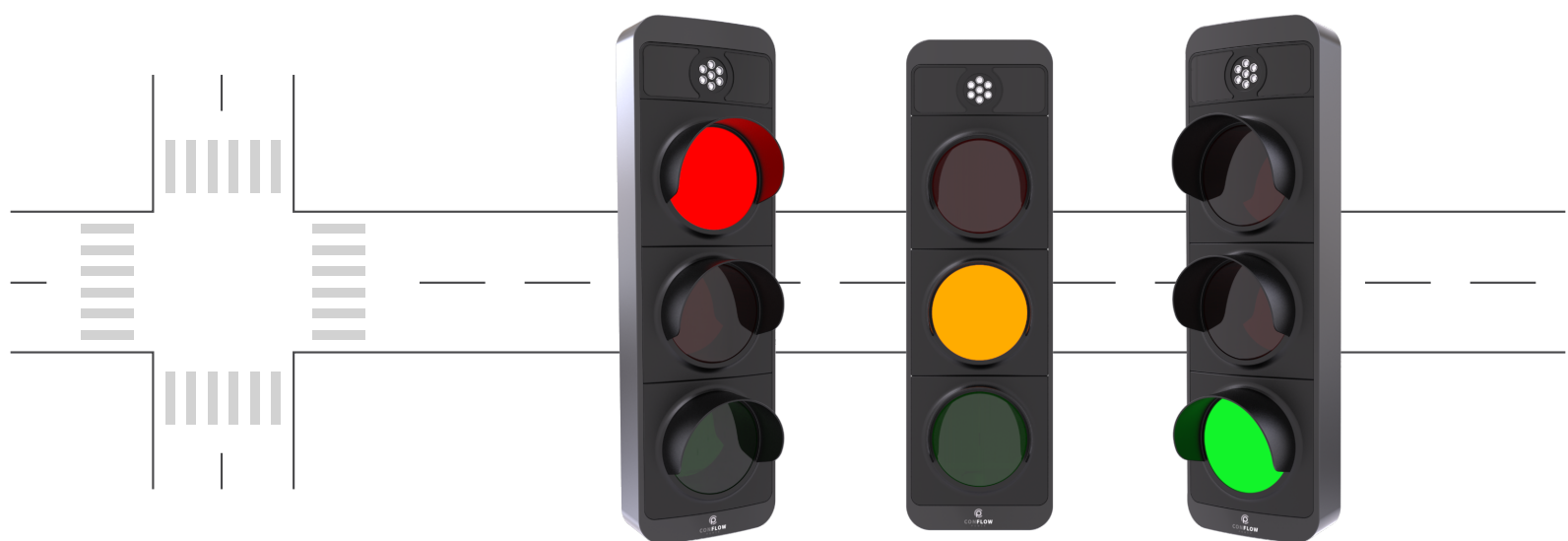

Drone Ready

Drone Ready is a cutting-edge Drone Guidance System, with an innovative landing pad that provides secure drone storage and charging.



DELIVERY

Automated and tracked drone packaged delivery systems



PREVENTING WILDFIRES

Remotely stationed drones used to detect and prevent wildfire



DETECTING POACHERS

Autonomous drones used to detect poachers across vast areas



AGAINST ILLEGAL LOGGING

Automated detecting and alerting against illegal logging in large areas.



IN RESEARCH

Research in remote, expansive and inaccessible areas.



AID DELIVERY

Delivery of medical and other aid to cut off, remote or dangerous areas.

5. Fundamental & Valuation Analysis

5.1 | Entity Progression and Sales Model

This year Conflow will further establish global reach through additional territorial based licencing sales of iLamp and connected technologies, creating a global distribution network while simultaneously proving out the developing Conflow technology stack in different environmental settings. Assisted by the licenses sales Conflow will continue to expand their IP portfolio as further hardware and software solutions are aggregated, towards the end of 2023 CPG will move into the next stages with each of it's new products: iTraffic, iStopSign, iMicro, iCharge and iTurbine.

5.2 | Mechanics of the license

ILOCX is a legal and technology framework, designed to bring innovation to life. ILOCX enables companies to issue and sell promotional licenses enabling them to raise money while boosting awareness by requiring buyers to actively promote the product licensed. In return the company issuing pays a royalty to the promoters.

Conflow Power listed on the ILOCX platform and after 2 rounds and over a million licenses sold it has increased in value almost 5 fold from \$2 to \$9.50 post the split in less than 3 years.

It is due to pay another royalty as soon as revenue from territorial license sales is booked and offers a 10% royalty from gross revenue to its license holders in exchange for the promotion they undertake on the company's behalf.

5.3 | Conflow Power is An IP Play With Lean Operating Structure

Conflow Power sells licenses for the use of its technology. Rather than sell its product outright, which would increase costs for buyers, its licensing model helps it to lower their costs while also protecting its IP. Conflow Power will sell territorial licenses to operating companies that install and manage the smart streetlights. The cost of these streetlights starts at \$5,300 MSRP and scales higher based on options, such as sensors, communications, audio/video and drone landing/charging stations. Conflow Power is the IP license holder and gets \$1,000 per streetlight plus an additional 10% royalty on all energy sales, and an additional revenue on all technology support service sales. The average smart streetlight consumes ~\$420 of electricity/year, thus if streetlights are renewably powered a portion of this cost savings comes back to the operator.

Let's assume a 40% discount to this average at \$250 of electricity per year per streetlight. 10% of that cost savings comes directly to Conflow Power Group, on average ~\$25/year per streetlight. This would suggest that the first planned number of poles could be worth \$2 million in royalties to Conflow Power and if we project 5% of the global market to use CFP technology within 10 years this royalty is \$400 million. For competitive reasons, Conflow Power isn't disclosing the breakout of related services, but has suggested that ancillary sales including energy savings could represent a large proportion of total annual revenue.

- Conflow Power has partnered with Power as a Service (PaaS) to convert what is usually an infrastructure cost into a solid revenue opportunity. Conflow Power's licensing model reduces the cost of energy for licensees who only pay according to use while providing them its highly specialised technology for harvesting energy. This is a sustainable royalty that is paid through cost savings.
- Promotional license Royalty payments are a percentage of the company's gross revenues. This gives greater clarity for future royalty payments since they are a percentage of contracted revenues. As licensee businesses grow and there is greater adoption of Conflow Power's products, royalty payments will increase as a percentage of increasing revenues. Investors can receive royalties from promotional licenses sold by the Conflow to companies looking for smart, low cost energy solutions for connected devices through purchase of promotional licenses as they have a role to play in its expansion, growth and marketing.

5.4 | Topline Growth Set to Accelerate

Conflow Power announced its off-grid smart street lighting solutions in May 2020 and announced a pilot for the off-grid streetlights with Conflow Power USA. In September 2020, Conflow announced the closing of USA license terms to Conflow USA Inc., for \$50 million, opening the U.S. market and the vast potential which comes with it.

- Conflow USA brings an immediate pilot for testing the integrated off-grid lighting system.
- The opportunity size is huge as there are 26,000,000 streetlights in America and Conflow Power Group has the most sophisticated and integrated on and off grid options on the market today.
- Conflow USA intends to embark on a mass roll out of the street lighting systems which run in-field diagnostics and data to improve battery technology and bring off-grid renewable energy systems into the mainstream as bankable products.

This license agreement has been designed to fit within the ILOCX Global Licensing Model (GLM). This structure ensures a fair and equitable relationship between both licensee and licensor as well as all other license holders within the family of licenses which Conflow Power Group issues. All participants in the GLM benefit from new technology or advancements in manufacturing by sharing these initiatives across license holders globally. In addition, all promotional license holders in Conflow Power Group's main board listing on the ILOCX benefit from revenue generated by global license holders, as well as iLamp and other Conflow Power products, as a percentage of that revenue is paid to Conflow Power Group Limited.

In addition to the anticipated successful execution of the U.S. contract, this growth will be driven by the company's go-to-market strategy that comprises the following three elements:

1. Strengthening market position in the U.S., UK, Australia, Canada, France and South East Asia (Thailand, Indonesia, Singapore, Malaysia, the Philippines, Vietnam, Myanmar, Brunei, Cambodia and Laos), and Latin America.
2. Expanding global reach with leading utility companies and industry experts.
3. Building strong partnership with technology innovators.

5.5 | Valuation and ILOCX Listing

Conflow is working closely with ILOCX to raise the requisite capital. ILOCX offers participants an opportunity to buy licenses to technologies and services being developed by cutting- edge, innovative companies.

Conflow has issued 3.3 million licenses which collectively legally own 10% of the company's gross revenue. Conflow sold 1.1 million units between \$2 and \$9.50 over the past 2 years. The licenses entitle the owners to share in a 10% royalty on Conflow Power's gross sales. Since then, Conflow Power has closed a series of joint ventures, acquisitions, and sector and territorial license sales for the technology.

Driven by strengthening fundamentals, Conflow's valuation has risen 5x since its ILO and ILOCX expects the price of the CFP license to rise significantly by 2026, as deals are closed and royalties are paid - making Conflow one of the best smart cities plays for a global audience of participants.

- On the news of its license sale in the U.S and the payment of its first royalty Conflow launched a Secondary License Offer at \$9.50 (\$95.00 Pre- Split), the proceeds of which will be used for manufacturing, prototyping, operations and acquisitions.

Recent Company News

April 12, 2022

ConFlow Power Group signs major deal for iLamps in the USA.

[Read More](#)

September 13, 2021

ConFlow Power Group closes £20,000,000 in structured finance.

[Read More](#)

April 27, 2021

ConFlow Power Group Announces development and manufacturing agreement in Taiwan.

[Read More](#)

October 25, 2020

Conflow and 4D Vision Light Joint Venture.

[Read More](#)

October 6, 2020

Conflow Power Group Ltd effects a 10 for 1 license split on the ILOCX and launches its Secondary Offer to License holders.

[Read More](#)

September 22, 2020

Conflow Power Sells USA Territory for \$50,000,000.

[Read More](#)

July 31, 2020

Streetlighting gets smarter with Conflow Power.

[Read More](#)

July 18, 2020

Reducing the Utility of Copper in Battery Technology.

[Read More](#)

May 20, 2020

Conflow Power Formalizes Group Structure.

[Read More](#)

April 12, 2020

Sustainable Battery Storage Solutions and Conflow Power's Unique Approach.

[Read More](#)

March 31, 2020

Conflow Power Steps Up its Focus on Lighting.

[Read More](#)

January 10, 2020

Tax on Air.

[Read More](#)

November 11, 2019

Conflow Power Signs Definitive License Agreement for Canada and France with Idea Capital via their Newly Formed Entity Conflow Power Canada Corp.

[Read More](#)

Risks

- Potential inability to protect and safeguard intellectual property from competition
- Geopolitical and macroeconomic risks arising from global nature of operations
- Regulatory risks arising from operations in multiple geographies
- Slower-than-expected adoption of smart cities and related ecosystem
- Integration risks associated with current and future acquisitions
- Financial health of end customers
- Dependence on management team and key personnel

Notes